

Module 4 Drives and Mechanisms

Lecture 1

Elements of CNC machine tools: electric motors

1. Drives

Basic function of a CNC machine is to provide automatic and precise motion control to its elements such work table, tool spindle etc. Drives are used to provide such kinds of controlled motion to the elements of a CNC machine tool. A drive system consists of drive motors and ball lead-screws. The control unit sends the amplified control signals to actuate drive motors which in turn rotate the ball lead-screws to position the machine table or cause rotation of the spindle.

2. Power drives

Drives used in an automated system or in CNC system are of different types such as electrical, hydraulic or pneumatic.

- **Electrical drives**

These are direct current (DC) or alternating current (AC) servo motors. They are small in size and are easy to control.

- **Hydraulic drives**

These drives have large power to size ratio and provide stepless motion with great accuracy. But these are difficult to maintain and are bulky. Generally they employ petroleum based hydraulic oil which may have fire hazards at upper level of working temperatures. Also hydraulic elements need special treatment to protect them against corrosion.

- **Pneumatic drives**

This drives use air as working medium which is available in abundant and is fire proof. They are simple in construction and are cheaper. However these drives generate low power, have less positioning accuracy and are noisy.

In CNC, usually AC, DC, servo and stepper electrical drives are used. The various drives used in CNC machines can be classified as:

- a. Spindle drives to provide the main spindle power for cutting action
- b. Feed drives to drive the axis

2.1 Spindle drives

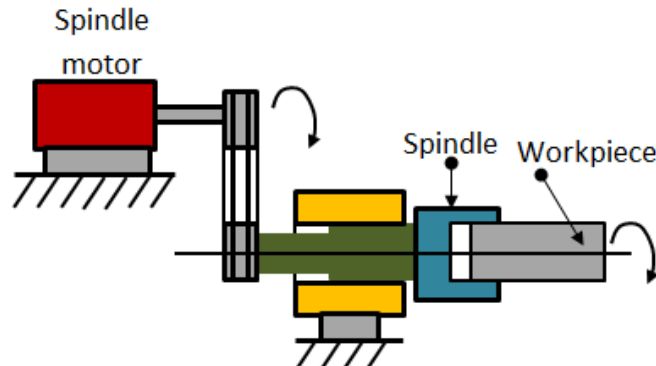

Fig. 4.1.1 Schematic of a spindle drive

The spindle drives are used to provide angular motion to the workpiece or a cutting tool. Figure 4.1.1 shows the components of a spindle drive. These drives are essentially required to maintain the speed accurately within a power band which will enable machining of a variety of materials with variations in material hardness. The speed ranges can be from 10 to 20,000 rpm. The machine tools mostly employ DC spindle drives. But as of late, the AC drives are preferred to DC drives due to the advent of microprocessor-based AC frequency inverter. High overload capacity is also needed for unintended overloads on the spindle due to an inappropriate feed. It is desirable to have a compact drive with highly smooth operation.

2.2 Feed Drives

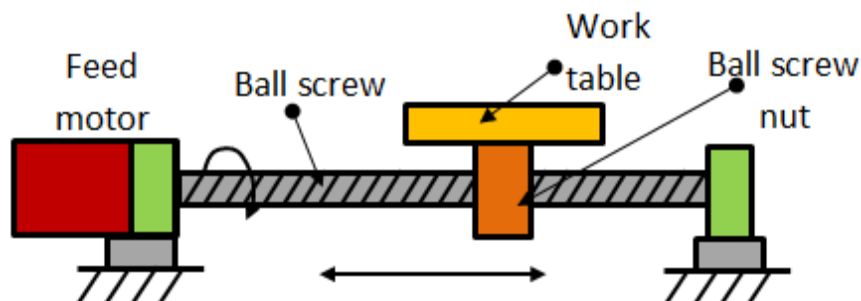

Fig. 4.1.2 Typical feed drive

These are used to drive the slide or a table. Figure 4.1.2 shows various elements of a feed drive. The requirements of an ideal feed drive are as follows.

- The feed motor needs to operate with constant torque characteristics to overcome friction and working forces.
- The drive speed should be extremely variable with a speed range of about 1: 20000, which means it should have a maximum speed of around 2000 rpm and at a minimum speed of 0.1 rpm.
- The feed motor must run smoothly.
- The drive should have extremely small positioning resolution.

- Other requirements include high torque to weight ratio, low rotor inertia and quick response in case of contouring operation where several feed drives have to work simultaneously.

Variable speed DC drives are used as feed drives in CNC machine tools. However now-a-days AC feed drives are being used.

3. *Electrical drives*

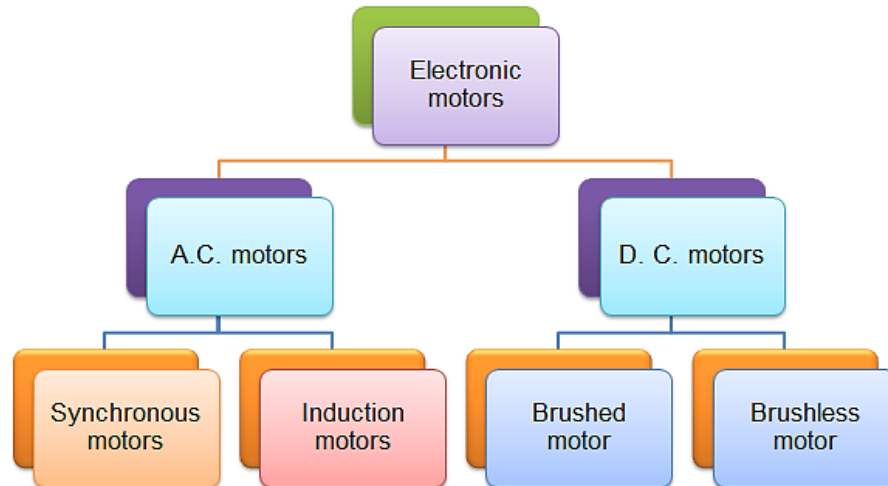

Fig. 4.1.3 Classification of motors

Electric drives are mostly used in position and speed control systems. The motors can be classified into two groups namely DC motors and AC motors (Fig. 4.1.3). In this session we shall study the operation, construction, advantages and limitations of DC and AC motors.

3.1. DC motors

A DC motor is a device that converts direct current (electrical energy) into rotation of an element (mechanical energy). These motors can further be classified into brushed DC motor and brushless DC motors.

3.1.1 *Brush type DC motor*

A typical brushed motor consists of an armature coil, slip rings divided into two parts, a pair of brushes and horse shoes electromagnet as shown in Fig. 4.1.4. A simple DC motor has two field poles namely a north pole and a south pole. The magnetic lines of force extend across the opening between the poles from north to south. The coil is wound around a soft iron core and is placed in between the magnet poles. These electromagnets receive electricity from an outside power source. The coil ends are connected to split rings. The carbon brushes are in contact with the split rings. The brushes are connected to a DC source. Here the split rings rotate with the coil while the brushes remain stationary.

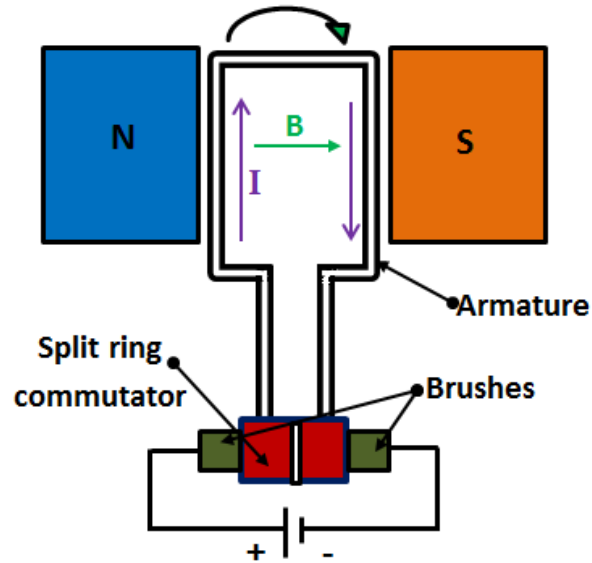

Fig. 4.1.4 Brushed DC motor

The working is based on the principle that when a current-carrying conductor is placed in a magnetic field, it experiences a mechanical force whose direction is given by Fleming's left-hand rule. The magnitude of the force is given by

$$F = BIL\sin\theta \quad (4.1.1)$$

Where, B is magnetic field density in weber/m²

I is the current in amperes and

L is the length of the conductor in meter

θ is the angle between the direction of the current in the conductor and the electric field

If the current and field are perpendicular then $\theta=90^\circ$. The equation 4.1.1 becomes,

$$F = BIL \quad (4.1.2)$$

A direct current in a set of windings creates a magnetic field. This field produces a force which turns the armature. This force is called torque. This torque will cause the armature to turn until its magnetic field is aligned with the external field. Once aligned the direction of the current in the windings on the armature reverses, thereby reversing the polarity of the rotor's electromagnetic field. A torque is once again exerted on the rotor, and it continues spinning. The change in direction of current is facilitated by the split ring commutator. The main purpose of the commutator is to overturn the direction of the electric current in the armature. The commutator also aids in the transmission of current between the armature and the power source. The brushes remain stationary, but they are in contact with the armature at the commutator, which rotates with the armature such that at every 180° of rotation, the current in the armature is reversed.

Advantages of brushed DC motor:

- The design of the brushed DC motor is quite simple
- Controlling the speed of a Brush DC Motor is easy
- Very cost effective

Disadvantages of brushed DC motor:

- High maintenance
- Performance decreases with dust particles
- Less reliable in control at lower speeds
- The brushes wear off with usage

3.1.2 Brushless DC motor

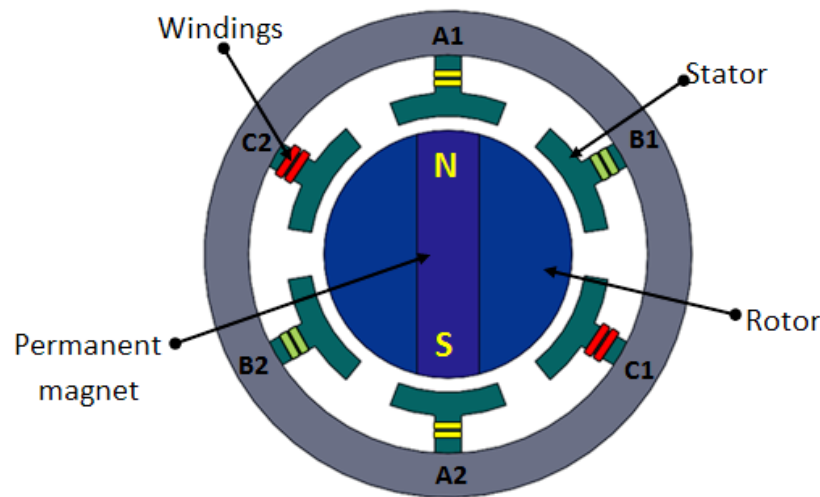

Fig. 4.1.5 Brushless DC motor

A brushless DC motor has a rotor with permanent magnets and a stator with windings. The rotor can be of ceramic permanent magnet type. The brushes and commutator are eliminated and the windings are connected to the control electronics. The control electronics replace the commutator and brushes and energize the stator sequentially. Here the conductor is fixed and the magnet moves (Fig. 4.1.5).

The current supplied to the stator is based on the position of rotor. It is switched in sequence using transistors. The position of the rotor is sensed by Hall effect sensors. Thus a continuous rotation is obtained.

Advantages of brushless DC motor:

- More precise due to computer control
- More efficient
- No sparking due to absence of brushes
- Less electrical noise
- No brushes to wear out
- Electromagnets are situated on the stator hence easy to cool
- Motor can operate at speeds above 10,000 rpm under loaded and unloaded conditions
- Responsiveness and quick acceleration due to low rotor inertia

Disadvantages of brushless DC motor:

- Higher initial cost
- Complex due to presence of computer controller
- Brushless DC motor also requires additional system wiring in order to power the electronic commutation circuitry

3.2AC motors

AC motors convert AC current into the rotation of a mechanical element (mechanical energy). As in the case of DC motor, a current is passed through the coil, generating a torque on the coil. Typical components include a stator and a rotor. The armature of rotor is a magnet unlike DC motors and the stator is formed by electromagnets similar to DC motors. The main limitation of AC motors over DC motors is that speed is more difficult to control in AC motors. To overcome this limitation, AC motors are equipped with variable frequency drives but the improved speed control comes together with a reduced power quality.

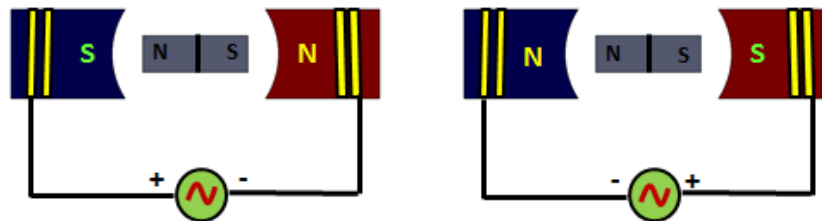

Fig. 4.1.6 AC motor working principle

The working principle of AC motor is shown in fig. 4.1.6. Consider the rotor to be a permanent magnet. Current flowing through conductors energizes the magnets and develops N and S poles. The strength of electromagnets depends on current. First half cycle current flows in one direction and in the second half cycle it flows in opposite direction. As AC voltage changes the poles alternate.

AC motors can be classified into synchronous motors and induction motors.

3.2.1 Synchronous motor

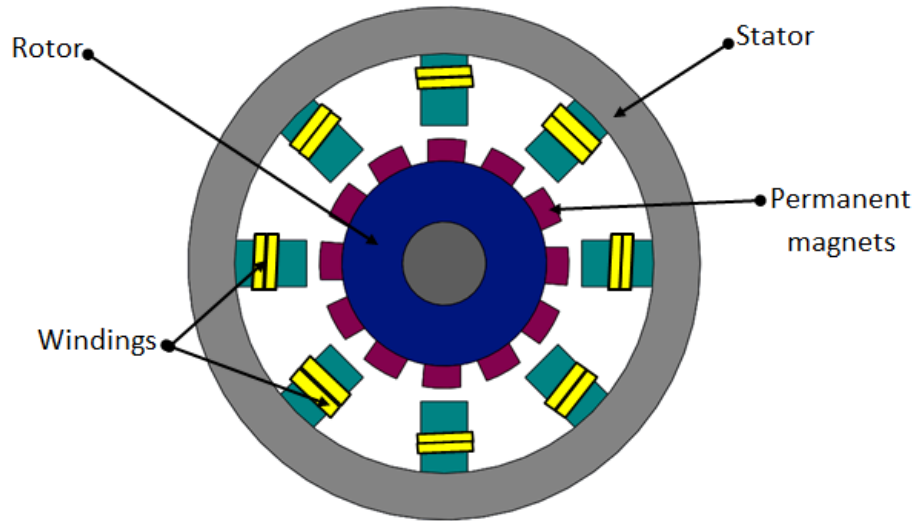

Fig. 4.1.7 Synchronous AC motor

A synchronous motor is an AC motor which runs at constant speed fixed by frequency of the system. It requires direct current (DC) for excitation and has low starting torque, and hence is suited for applications that start with a low load. It has two basic electrical parts namely stator and rotor as shown in fig. 4.1.7. The stator consists of a group of individual wound electro-magnets arranged in such a way that they form a hollow cylinder. The stator produces a rotating magnetic field that is proportional to the frequency supplied. The rotor is the rotating electrical component. It also consists of a group of permanent magnets arranged around a cylinder, with the poles facing toward the stator poles. The rotor is mounted on the motor shaft. The main difference between the synchronous motor and the induction motor is that the rotor of the synchronous motor travels at the same speed as the rotating magnet.

The stator is given a three phase supply and as the polarity of the stator progressively change the magnetic field rotates, the rotor will follow and rotate with the magnetic field of the stator. If a synchronous motor loses lock with the line frequency it will stall. It cannot start by itself, hence has to be started by an auxiliary motor.

Synchronous speed of an AC motor is determined by the following formula:

$$N_s = \frac{120 * f}{P} \quad (4.1.3)$$

N_s = Revolutions per minute

P = Number of pole pairs

f = Applied frequency

3.2.2 Induction motor

Induction motors are quite commonly used in industrial automation. In the synchronous motor the stator poles are wound with coils and rotor is permanent magnet and is supplied with current to create fixed polarity poles. In case of induction motor, the stator is similar to synchronous motor with windings but the rotors' construction is different.

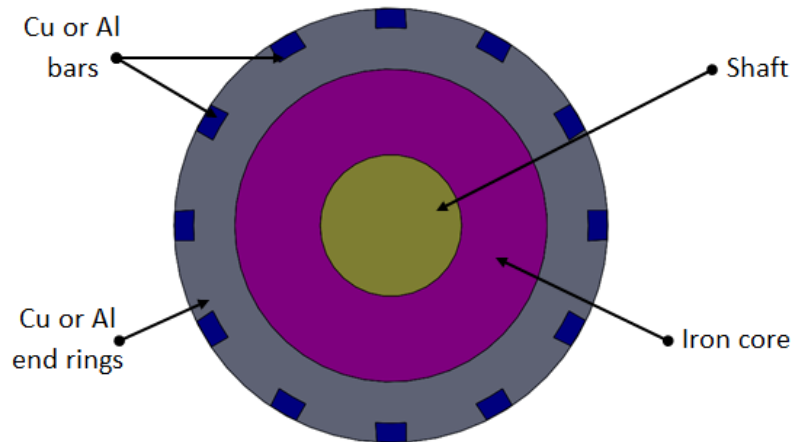

Fig. 4.1.8 Induction motor rotor

Rotor of an induction motor can be of two types:

- A squirrel-cage rotor consists of thick conducting bars embedded in parallel slots. The bars can be of copper or aluminum. These bars are fitted at both ends by means end rings as shown in figure 4.1.8.
- A wound rotor has a three-phase, double-layer, distributed winding. The rotor is wound for as many numbers of poles as the stator. The three phases are wired internally and the other ends are connected to slip-rings mounted on a shaft with brushes resting on them.

Induction motors can be classified into two types:

- *Single-phase induction motor*: It has one stator winding and a squirrel cage rotor. It operates with a single-phase power supply and requires a device to start the motor.
- *Three-phase induction motor*: The rotating magnetic field is produced by the balanced three-phase power supply. These motors can have squirrel cage or wound rotors and are self-starting.

In an induction motor there is no external power supply to rotor. It works on the principle of induction. When a conductor is moved through an existing magnetic field the relative motion of the two causes an electric current to flow in the conductor. In an induction motor the current flow in the rotor is not caused by any direct connection of the conductors to a voltage source, but rather by the influence of the rotor conductors cutting across the lines of flux produced by the stator magnetic fields. The induced current which is produced in the rotor results in a magnetic field around the rotor. The magnetic field around each rotor conductor will cause the rotor conductor to act like the permanent

magnet. As the magnetic field of the stator rotates, due to the effect of the three-phase AC power supply, the induced magnetic field of the rotor will be attracted and will follow the rotation. However, to produce torque, an induction motor must suffer from slip. Slip is the result of the induced field in the rotor windings lagging behind the rotating magnetic field in the stator windings. The slip is given by,

$$S = \frac{\text{Synchronous speed} - \text{Actual speed}}{\text{Synchronous speed}} * 100\% \quad (4.1.4)$$

Advantages of AC induction motors

- It has a simple design, low initial cost, rugged construction almost unbreakable
- The operation is simple with less maintenance (as there are no brushes)
- The efficiency of these motors is very high, as there are no frictional losses, with reasonably good power factor
- The control gear for the starting purpose of these motors is minimum and thus simple and reliable operation

Disadvantages of AC induction motors

- The speed control of these motors is at the expense of their efficiency
- As the load on the motor increases, the speed decreases
- The starting torque is inferior when compared to DC motors

Module 4 Drives and Mechanisms

Lecture 2

Stepper motors and Servo motors

1. Stepper motor

A stepper motor is a pulse-driven motor that changes the angular position of the rotor in steps. Due to this nature of a stepper motor, it is widely used in low cost, open loop position control systems.

Types of stepper motors:

- Permanent Magnet
 - Employ permanent magnet
 - Low speed, relatively high torque
- Variable Reluctance
 - Does not have permanent magnet
 - Low torque

1.1 Variable Reluctance Motor

Figure 4.2.1 shows the construction of Variable Reluctance motor. The cylindrical rotor is made of soft steel and has four poles as shown in Fig.4.2.1. It has four rotor teeth, 90° apart and six stator poles, 60° apart. Electromagnetic field is produced by activating the stator coils in sequence. It attracts the metal rotor. When the windings are energized in a reoccurring sequence of 2, 3, 1, and so on, the motor will rotate in a 30° step angle. In the non-energized condition, there is no magnetic flux in the air gap, as the stator is an electromagnet and the rotor is a piece of soft iron; hence, there is no detent torque. This type of stepper motor is called a variable reluctance stepper.

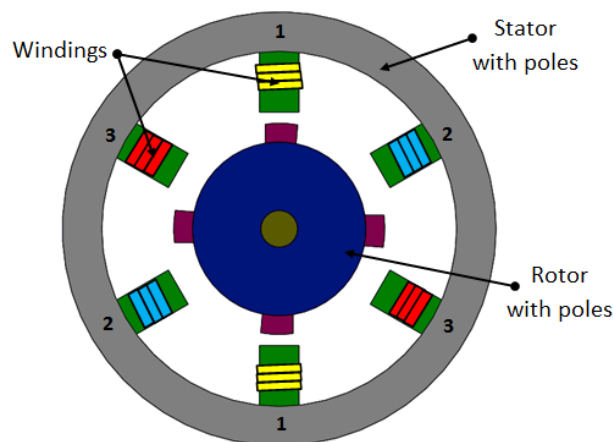

Fig. 4.2.1 Variable reluctance stepper motor

1.2 Permanent magnet (PM) stepper motor

In this type of motor, the rotor is a permanent magnet. Unlike the other stepping motors, the PM motor rotor has no teeth and is designed to be magnetized at a right angle to its axis. Figure 4.2.2 shows a simple, 90° PM motor with four phases (A-D). Applying current to each phase in sequence will cause the rotor to rotate by adjusting to the changing magnetic fields. Although it operates at fairly low speed, the PM motor has a relatively high torque characteristic. These are low cost motors with typical step angle ranging between 7.5° to 15°.

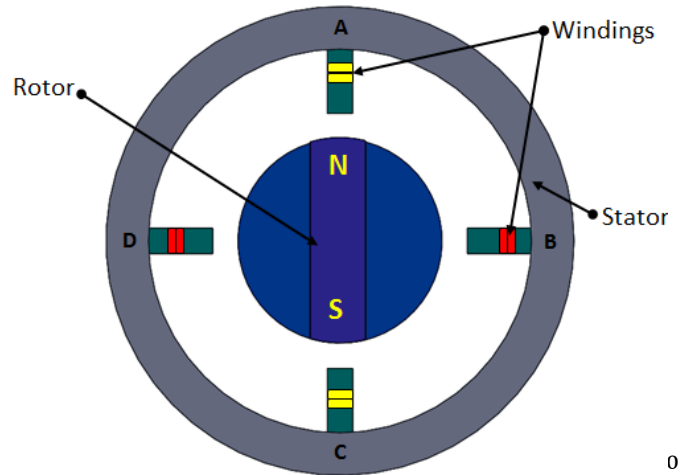

Fig. 4.2.2 Permanent magnet stepper

1.3 Hybrid stepper motor

Hybrid stepping motors combine a permanent magnet and a rotor with metal teeth to provide features of the variable reluctance and permanent magnet motors together. The number of rotor pole pairs is equal to the number of teeth on one of the rotor's parts. The hybrid motor stator has teeth creating more poles than the main poles windings (Fig. 4.2.3).

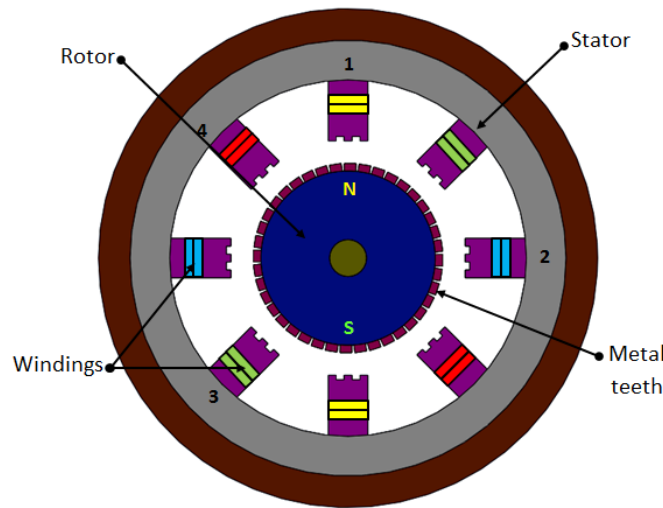

Fig. 3 Hybrid stepper motor

Rotation of a hybrid stepping motor is produced in the similar fashion as a permanent magnet stepping motor, by energizing individual windings in a positive or negative direction. When a winding is energized, north and south poles are created, depending on the polarity of the current flowing. These generated poles attract the permanent poles of the rotor and also the finer metal teeth present on rotor. The rotor moves one step to align the offset magnetized rotor teeth to the corresponding energized windings. Hybrid motors are more expensive than motors with permanent magnets, but they use smaller steps, have greater torque and maximum speed.

Step angle of a stepper motor is given by,

$$\text{Step angle} = \frac{360^\circ}{\text{Number of poles}} \quad (4.2.1)$$

Advantages of stepper motors

- Low cost
- Ruggedness
- Simplicity of construction
- Low maintenance
- Less likely to stall or slip
- Will work in any environment
- Excellent start-stop and reversing responses

Disadvantages of stepper motors

- Low torque capacity compared to DC motors
- Limited speed
- During overloading, the synchronization will be broken. Vibration and noise occur when running at high speed.

2. Servomotor

Servomotors are special electromechanical devices that produce precise degrees of rotation. A servo motor is a DC or AC or brushless DC motor combined with a position sensing device. Servomotors are also called control motors as they are involved in controlling a mechanical system. The servomotors are used in a closed-loop servo system as shown in Figure 4.2.4. A reference input is sent to the servo amplifier, which controls the speed of the servomotor. A feedback device is mounted on the machine, which is either an encoder or resolver. This device changes mechanical motion into electrical signals and is used as a feedback. This feedback is sent to the error detector, which compares the actual operation with that of the reference input. If there is an error, that error is fed directly to the amplifier, which will be used to make necessary corrections in control action. In many servo systems, both velocity and position are monitored. Servomotors provide accurate speed, torque, and have ability of direction control.

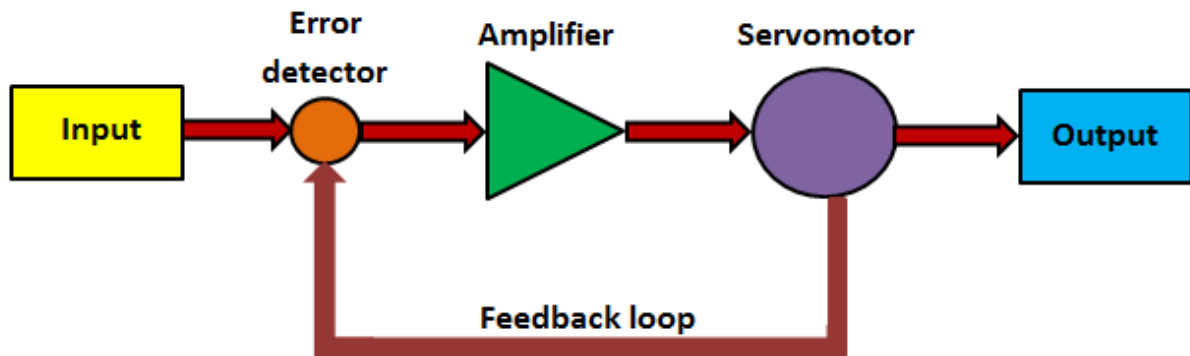

Fig. 4.2.4 Servo system block diagram

2.1 DC servomotors

DC operated servomotors are usually respond to error signal abruptly and accelerate the load quickly. A DC servo motor is actually an assembly of four separate components, namely:

- DC motor
- gear assembly
- position-sensing device
- control circuit

2.2. AC servo motor

In this type of motor, the magnetic force is generated by a permanent magnet and current which further produce the torque. It has no brushes so there is little noise/vibration. This motor provides high precision control with the help of high resolution encoder. The stator is composed of a core and a winding. The rotor part comprises of shaft, rotor core and a permanent magnet.

Digital encoder can be of optical or magnetic type. It gives digital signals, which are in proportion of rotation of the shaft. The details about optical encoder have already discussed in Lecture 3 of Module 2.

Advantages of servo motors

- Provides high intermittent torque, high torque to inertia ratio, and high speeds
- Work well for velocity control
- Available in all sizes
- Quiet in operation
- Smoother rotation at lower speeds

Disadvantages of servo motors

- More expensive than stepper motors
- Require tuning of control loop parameters
- Not suitable for hazardous environments or in vacuum
- Excessive current can result in partial demagnetization of DC type servo motor